

INSTALLATION

Install the brackets inside of the aluminum bars

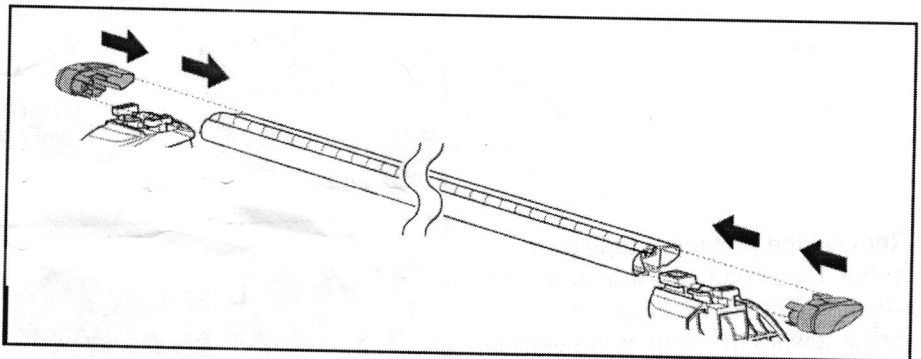

1) Use a flat-blade screwdriver to twist the lock plug, and remove the covers.

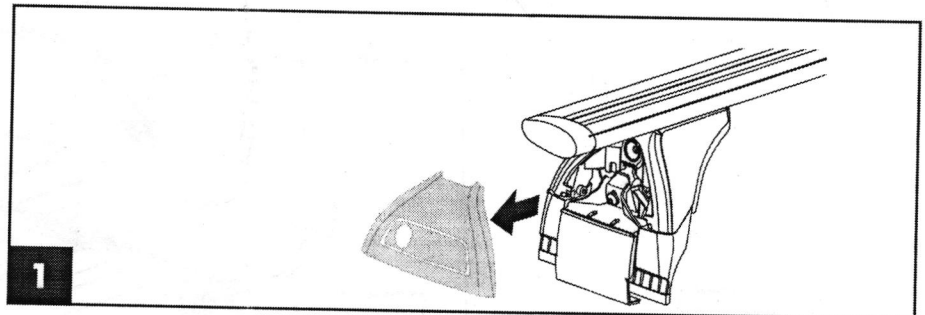

2) Loosen clip bolts using 4mm Allen wrench. Do not remove.

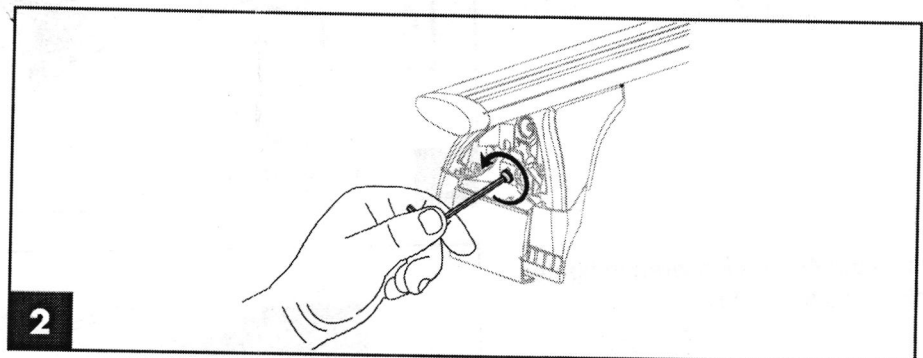

5) Remove the protective tape from crossbar. Place one crossbar in the front position. Orient the thick side of the crossbar toward the front of the vehicle.

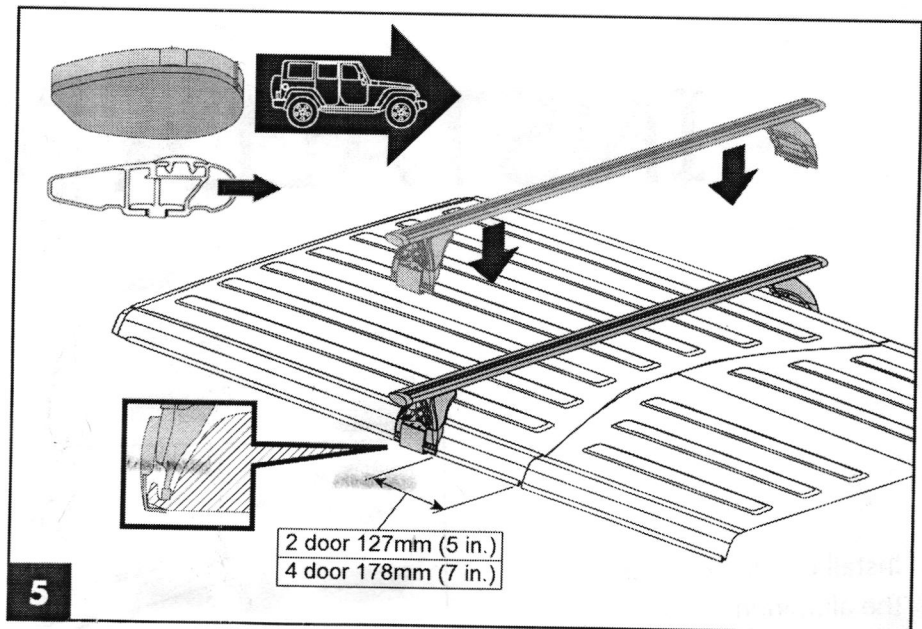

6) Remove the protective tape from crossbar. Place one crossbar in the rear position. Orient the thick side of the crossbar toward the front of the vehicle.

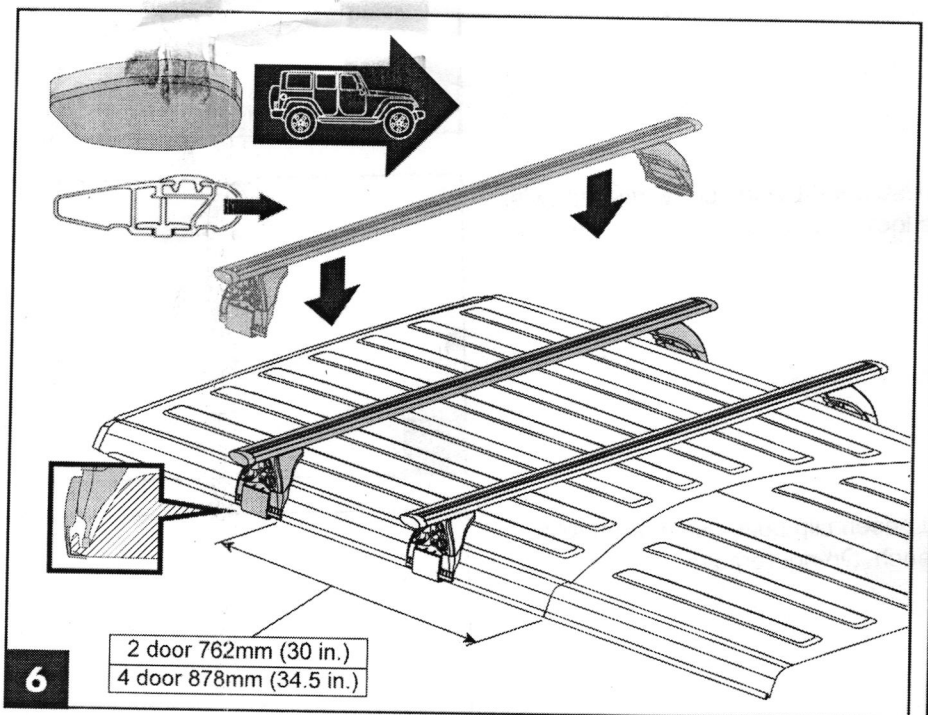

7) Using the 4mm Allen wrench tighten the clip bolts to 3.5 Nm.

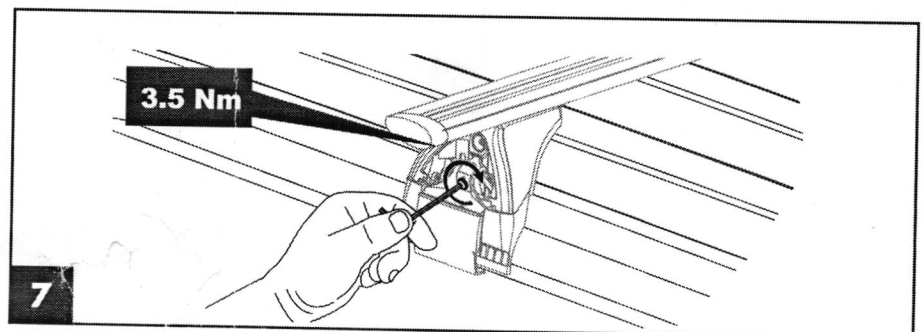

3) Do not attach crossbar to removable panels.

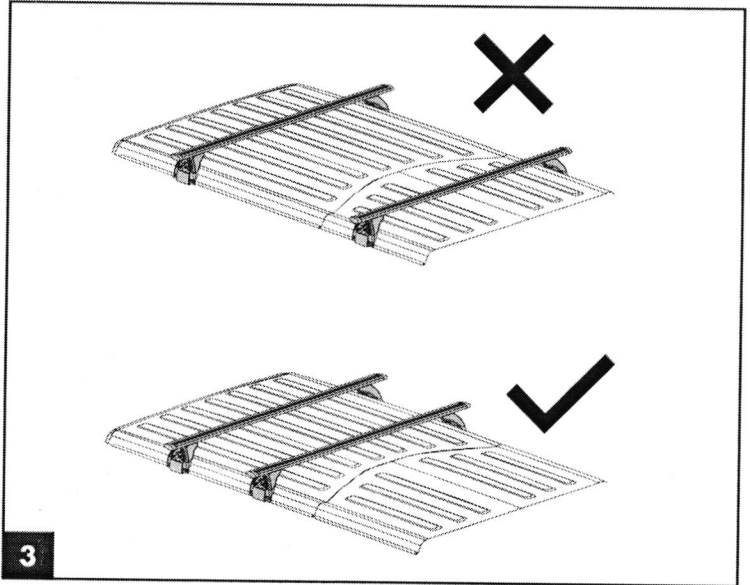

4) If necessary, tower spacing can be adjusted. Use the 4mm Allen wrench to loosen tower screw 1-2 turns. Adjust spacing, and re-tighten to 3.5 Nm.

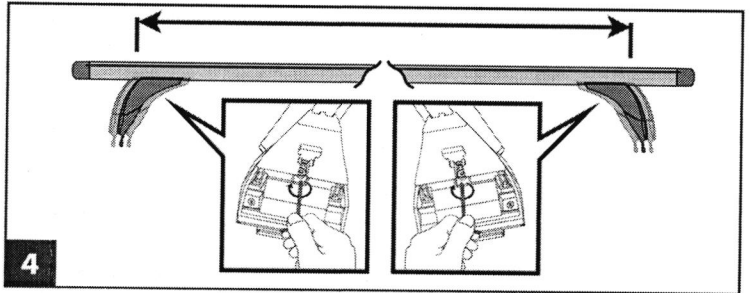

8) Check that the system is tight, re-tighten if necessary.

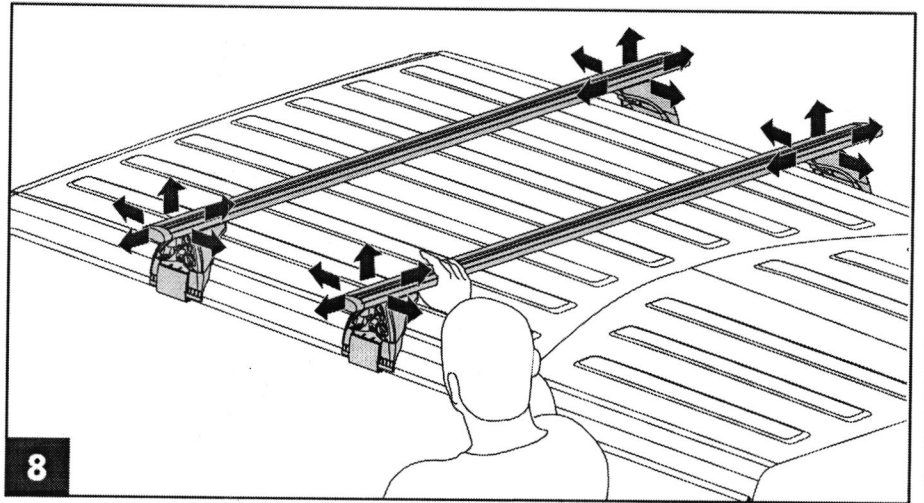

9) Replace covers.

